

2 Winkel 20x20 550 lang

alle Löcher $\varnothing 4,5$ auf Winkel übertragen
sowie die 4 äußeren Löcher $\varnothing 5,5$

Löcher von unten senken.

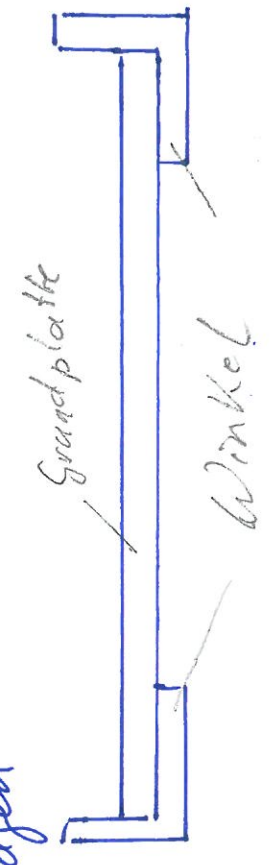

Montageplatte

Montage reihenfolge: Grundplatte + Winkel + Hutschne

- 1 Stk Hutschne 115 lang
- 2 x Winkel 20 x 20 45 lang

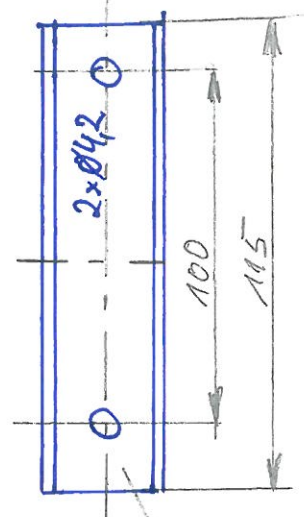
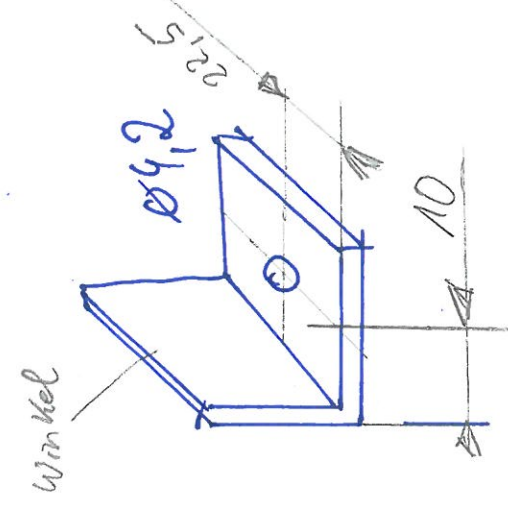
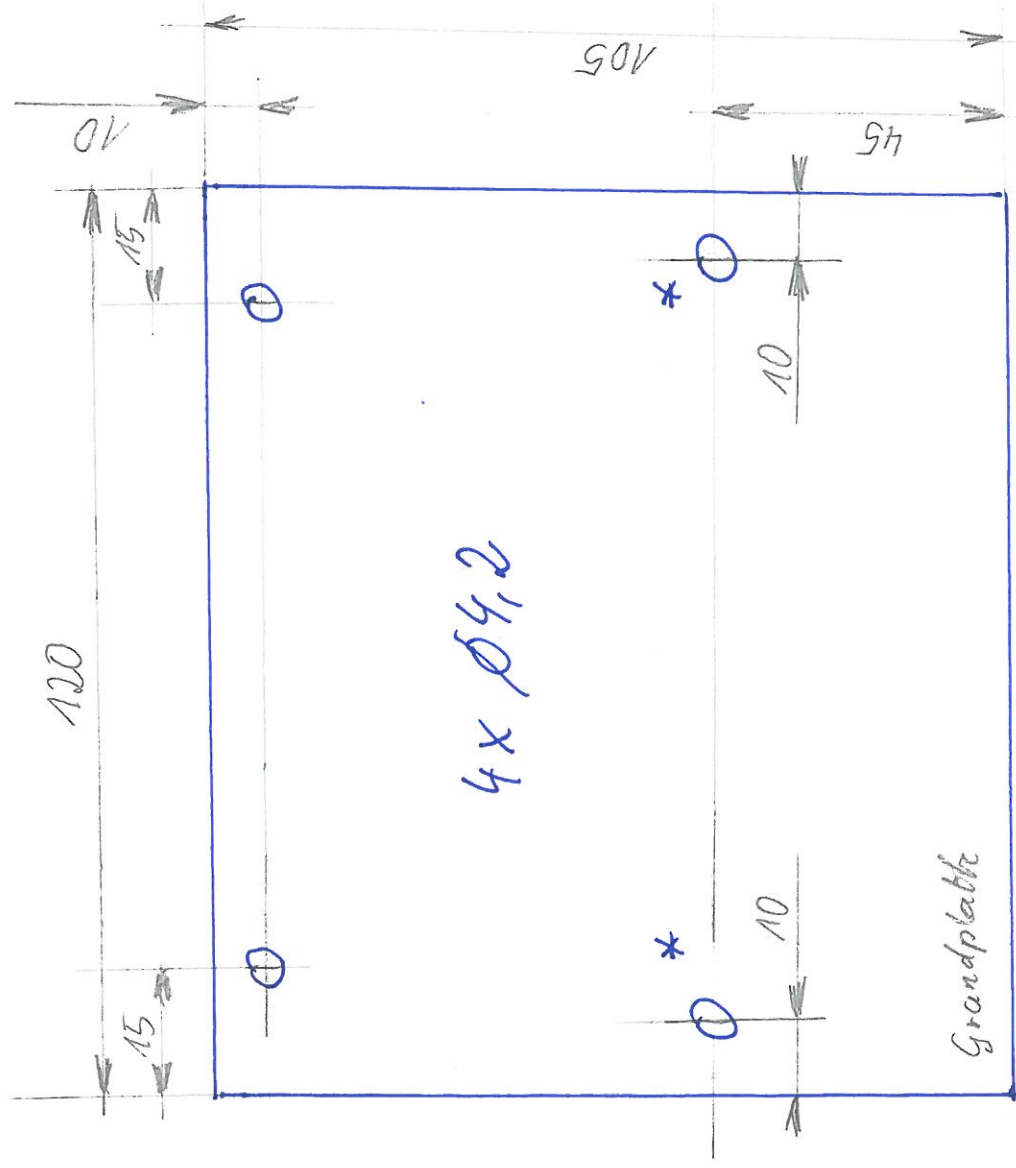

* von Unterseite senken

Sicherungsring
Keise für

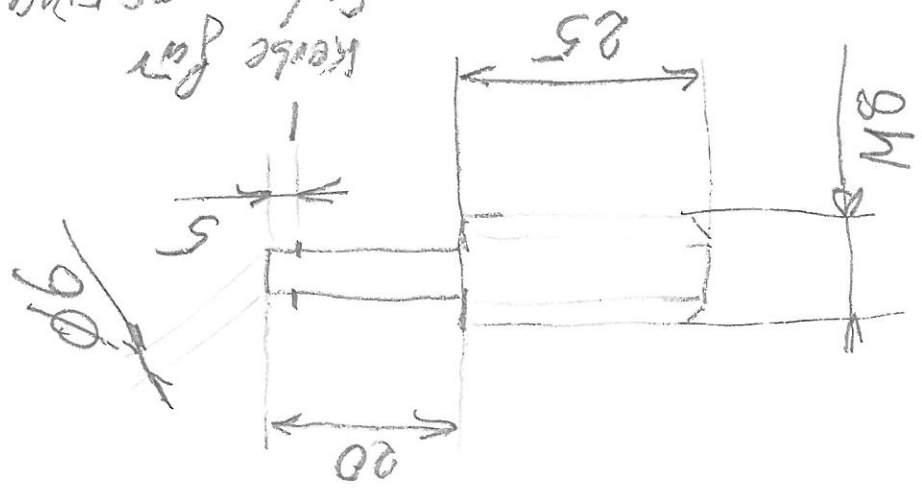

Ø 5,5

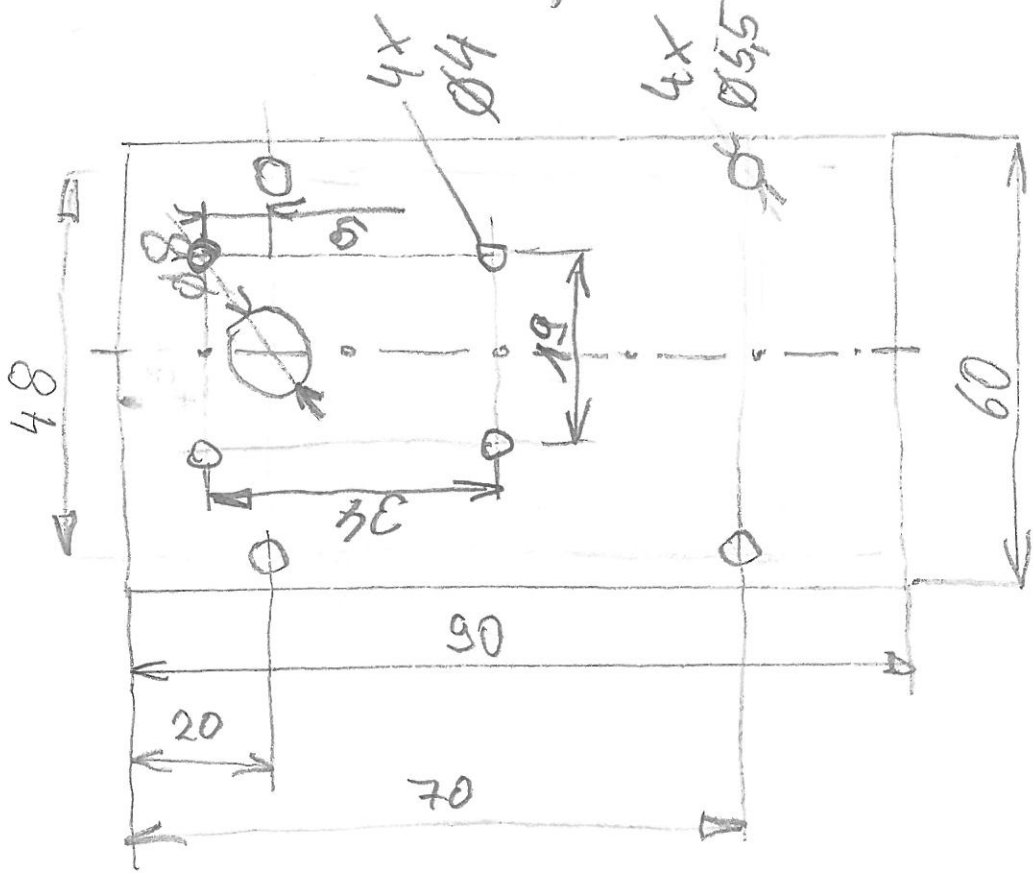
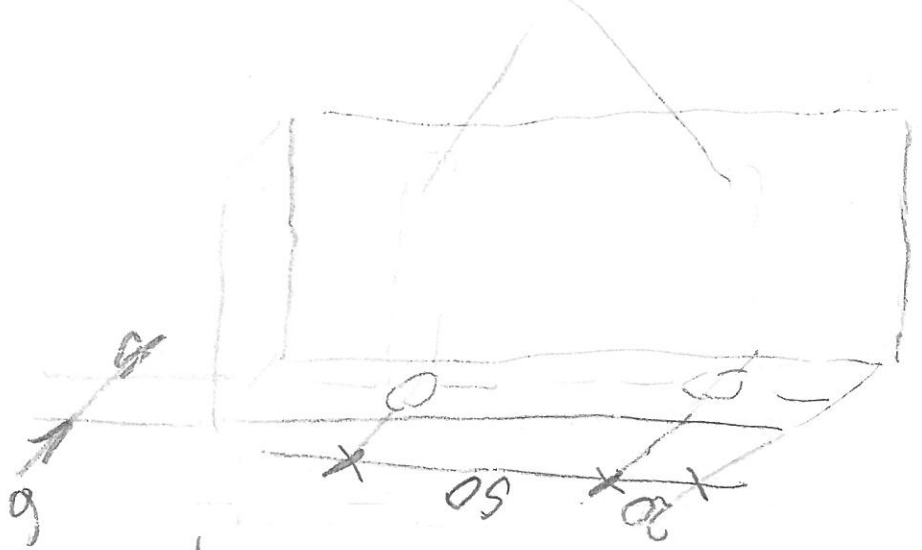

Grundplatte:
2 Stück: 60x90

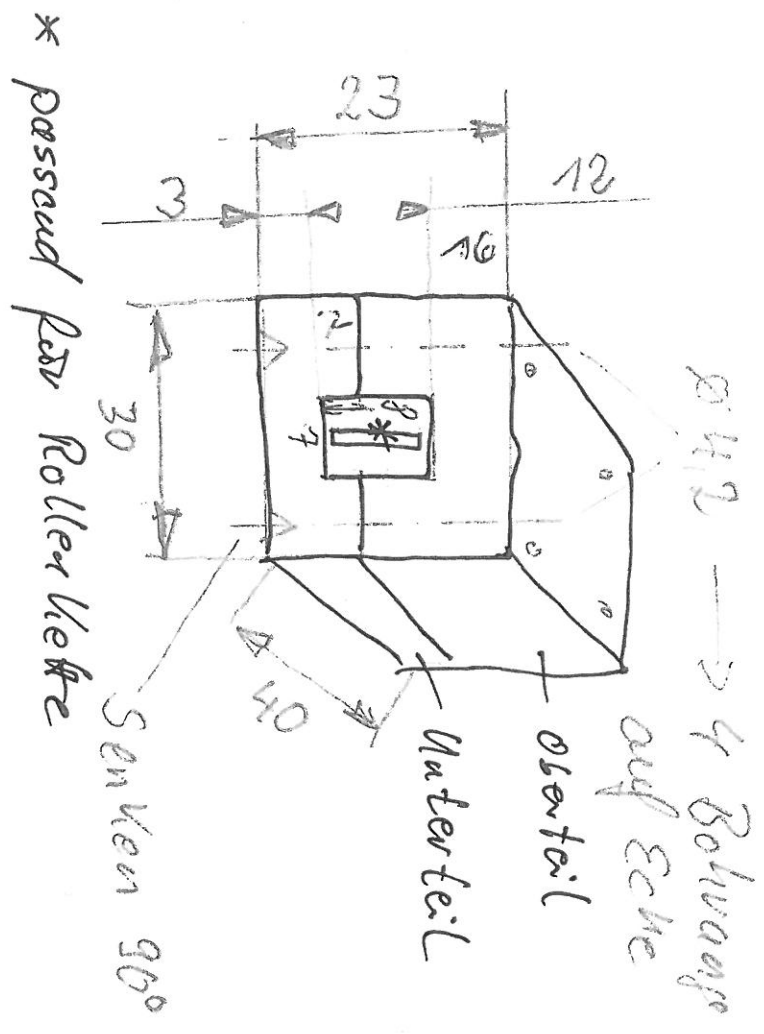

Ein steller zeit schaltuhr

THC15A WEEKLY PROGRAMMABLE TIMER

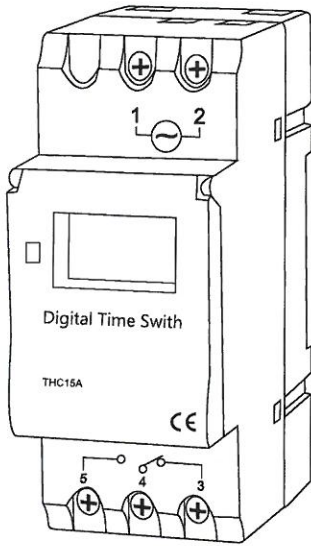

DIN Rail Installation

- Advanced pre-setting one week before
- Digital electronic time switch with daily programs
- Repeat programs with 16 on/off setting; and manual over-ride
- Lithium battery power reserve
- Auto time error correction ± 60 sec, weekly

TECHNICAL DATA

- Voltage rating: AC 220V 50/60Hz
- Voltage limit: AC 180V~250V
- Hysteresis: ≤ 1 sec/day (25°C)
- ON/OFF operation: 17 ON & 17OFF
- Power consumption: 2VA(max)
- Display: LCD
- Service life: Mechanically 10^7
Electrically 10^8
- Minimum interval: 1 minute
- Weight: approx 150g

Order voltage

12V, 24V, 36V, 48V, 110V;

Count down: 1 sec-99 min 56 sec

Pulse: 1 sec-59 min 59 sec

Load capacity: resistive load: 16A/250V AC

Lagging load: 10A/250Vac

lamp load: 2000W

Switching contact: 1 changeover switch

Power reserve: 3 years (Lithium battery)

Ambient temperature: -10~+40°C

Ambient humidity: 35~85%RH

CONNECTION DIAGRAM

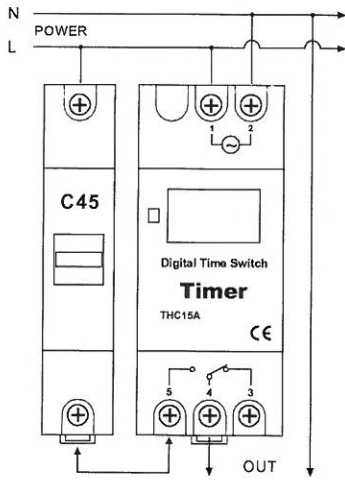

DISPLAY



Tag
Stunde / Minuten

auf "Auto"

MEANING.

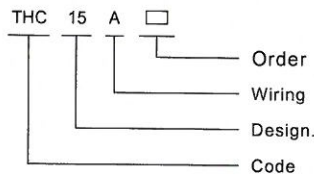

Timer nummer

Operating Instruction:

- To start switch: press reset Key. At the first time, if you want to the present time, please press "⊖" On board, then press D+, H+, M+ to adjust the number to the present time.
- Enter into programming as belows:

Step	Key	Programming
1	Press P	Setting 1 ON time (display 1 on)
2	Press H+ / M+	Setting hours and minutes
3	Press D+	To select same every day, or different time each day
4	Press P	Setting 1 off time (display 1 off)
5	Press H+ / M+	Setting hours and minutes turn off time
6	Press D+	If you want the same every day, you need not press this key
7	Repeat step 2-6	Set 2-17 on/off time
8	Press ⊖	End

If you do not require 17 settings, press "⊖" to the end.

NOTE:

- Time setting should according to the time sequence, couldn't be set crossly
- System with quit automatically if there's no operating within 10 seconds and no data is saved.
- Function 3,4,5 can not be used simultaneously.

DIMENSIONS

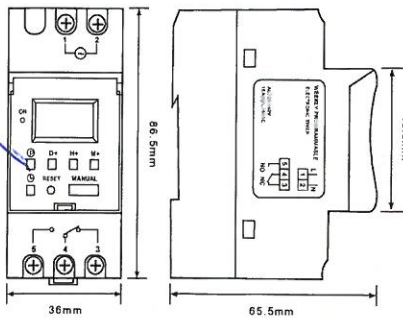

H+ Stunden
M+ Minuten

D+ Tag

Manual auf "Auto" stellen im Displ.

Programmieren

D